

MADJAX[®]

Part # 16-050 (6" LIFT)
& 16-051 (4" LIFT)

MadJax King XD Lift Kit

(will fit 2004+ Club Car Precedent/Tempo)



SCAN CODE TO WATCH
INSTALLATION VIDEO



ITEMS INCLUDED

- Main Suspension Assembly
- Driver Side Spindle
- Passenger Side Spindle
- Driver Side Upper A-arm Assembly
- Passenger Side Upper A-arm Assembly
- 2 Rear Axle Risers (16-050 has 2 tall & 2 short depending on rear springs)
- 2 Rear Shock Plates
- 2 Square U-Bolts
- Hardware Pack
- Thread Lock Adhesive

TOOLS NEEDED

- Ratchet
- Torque Wrench
- 10mm Socket
- 13mm Socket
- 17mm Socket
- 17mm Deep Well Socket
- 18mm Socket
- 19mm Socket
- 9/16" Socket
- 1/2" Socket
- 5/8" Socket
- 13/16" Socket
- 10mm Wrench
- 12mm Wrench
- 13mm Wrench
- 17mm Wrench
- 19mm Wrench
- 6mm Allen Wrench

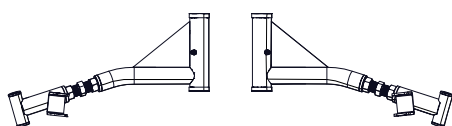
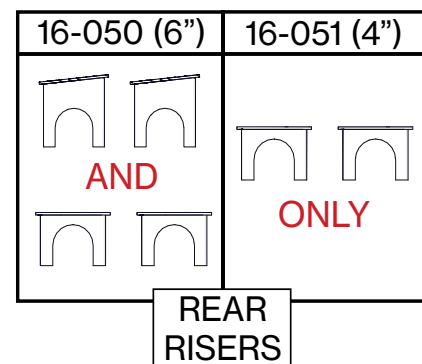
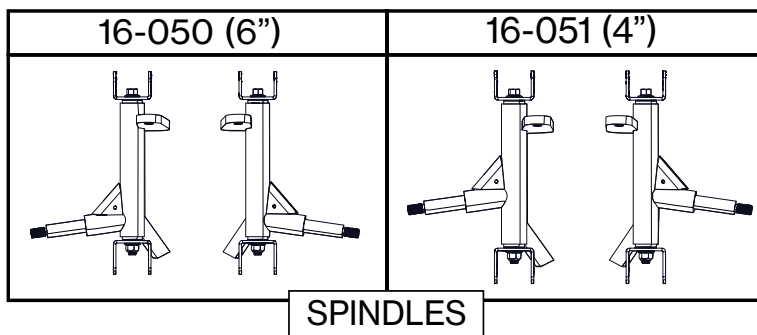

UPPER A-ARMS

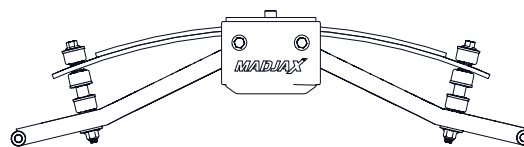

MAIN SUSPENSION
SUBASSEMBLY



REAR SHOCK
PLATES

WARNING:

After installing this lift kit, the front wheels must be properly aligned. Failure to properly align the front wheels may result in decreased ability to control the Golf Cart which may result in a rollover or crash.



WARNING



- To reduce risk of accidents and injury or death -

Be Prepared

- Wear seat belt, motorcycle helmet, eye protection and protective gear.

- Keep your body completely inside the vehicle at all times. Keep both hands on the steering wheel. Be sure passenger is seated, belted, and holding onto the handholds.

Be Qualified and Responsible

- This vehicle is intended for use only by an operator 16 or older with a valid motor vehicle license.

- Passenger and driver must be able to place both feet flat on the floorboard while seated upright with their backs against the seat backs.



Avoid Rollovers and Crushing Injuries

- Use care when turning:

- Turning the steering wheel too far or too fast can result in a rollover or loss of control.

- Slow down before entering a turn.

- When making tight turns from a stop, or at slow speeds, avoid sudden or hard acceleration.

- Avoid sideways sliding, skidding, or fishtailing, and never do donuts.

- Drive straight up and down inclines, not across them, if crossing a hill is unavoidable, drive slowly and turn downhill immediately if you feel the vehicle may tip.

Abrupt maneuvers or aggressive driving have caused rollovers- even on flat, open areas

**MUST BE
16 or Older**



DACROMET COATED	HARDWARE	QUANTITY
FRONT SUSPENSION ASSEMBLY	M10 X 55mm HEX BOLT	4
	M10 FLAT WASHER	4
	M10 LOCKWASHER	4
SPINDLES	M10 X 80mm HEX BOLT	4
	M10 FLAT WASHER	8
	M10 NYLOCK NUT	4
FRONT SHOCKS	M8 X 50mm HEX BOLT	2
	M8 FLAT WASHER	4
	M8 NYLOCK NUT	2
STEERING	2mm X 25mm COTTER PIN	2
REAR LOWER SHOCK BRACKETS	M8 X 25mm SOCKET HEAD CAP SCREW	2
	M8 FLAT WASHER	4
	M8 NYLOCK NUT	2
REAR RISERS	M10, 85mm X 150MM SQUARE U-BOLT	2
	M10 FLAT WASHER	4
	M10 NYLOCK NUT	4

STEP 1

 13mm, 19mm, and 13/16" SOCKETS, 10mm WRENCH

Engage the parking brake and place the front of the vehicle on jack stands under front frame. Ensure the front is raised high enough to accommodate the new lift and larger tires.

(A) Remove the front bumper, front wheels, and both **(B)** front hubs, save all the hardware, bumper, & front hubs for reinstallation.

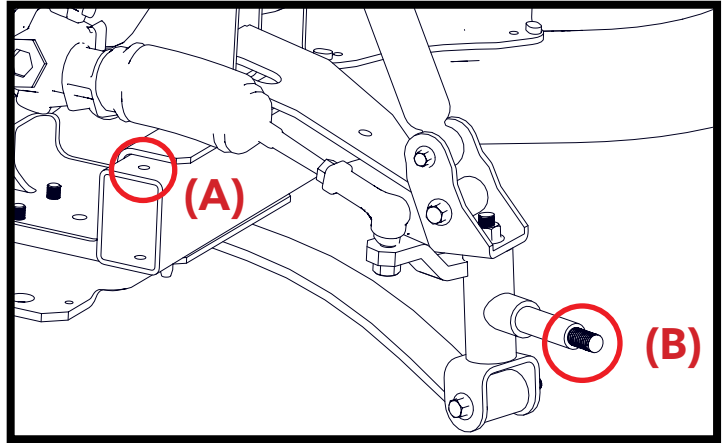

STEP 2

 13mm & 18mm SOCKETS, 17mm WRENCH

Uninstall the steering tie rod end from each spindle, retaining the hardware for later use.

Remove the lower mount bolt for each front shock from each spindle. Push the shocks up and out of the way.

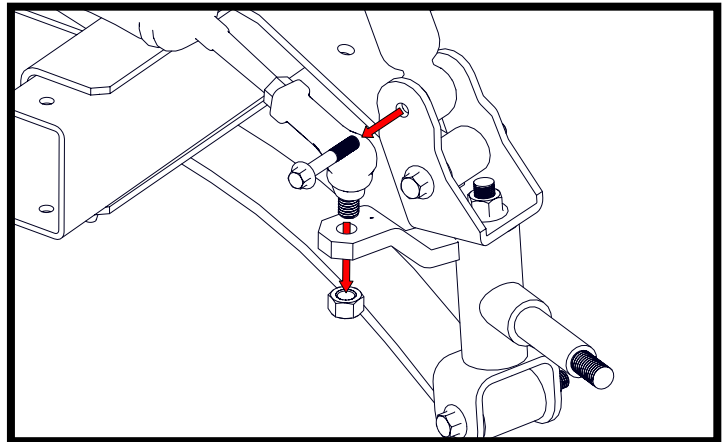

STEP 3

 13mm SOCKET

Remove the bolts that secure the steering rack to the frame, but **do not** detach from the steering shaft nor remove the steering rack from the vehicle. Retain the bolts.

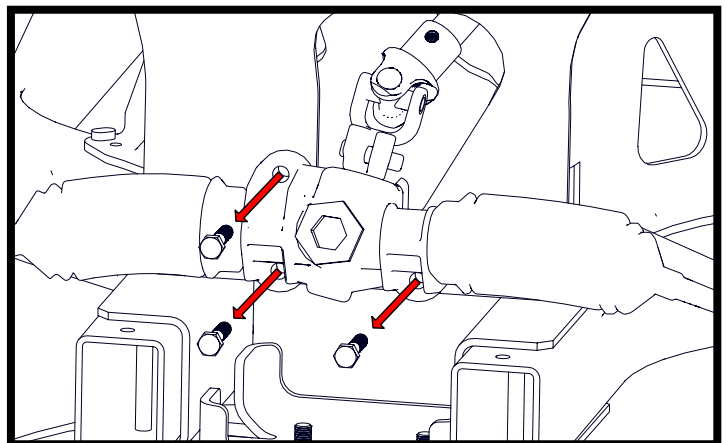

DO NOT REMOVE STEERING RACK FROM VEHICLE

STEP 4



13mm SOCKET

Move the steering rack out of the way in order to gain access to the upper a-arm mount bolts.

Remove these bolts and retain for installation of new A-Arms.

NOTE: After the next step the front suspension components will be free from the cart, use caution when removing spring and plate.

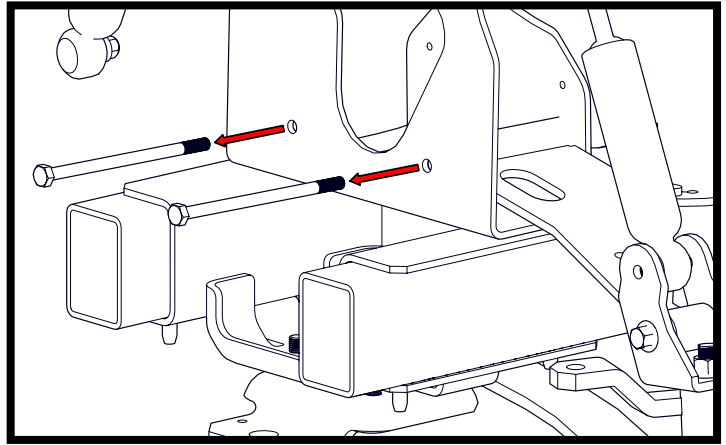

STEERING RACK NOT SHOWN FOR CLARITY

STEP 5



13mm SOCKET

Remove the tow bar bracket that is holding the stock leaf spring to the frame.

Discard the leaf spring, spindles, upper a-arms, and hardware, but retain the tow bar bracket.

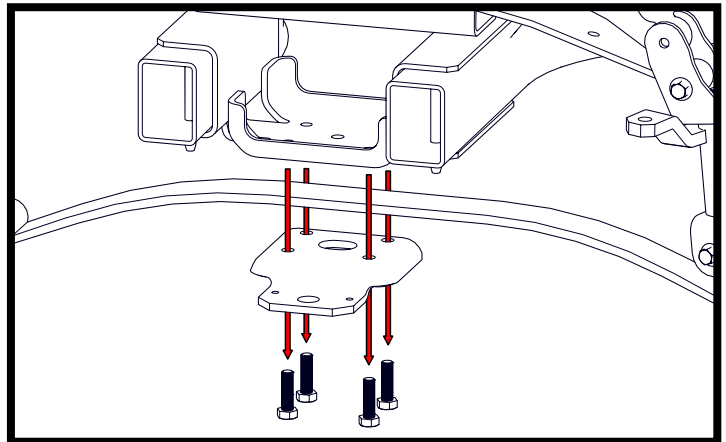

STEERING RACK NOT SHOWN FOR CLARITY

STEP 6



13mm SOCKET

Using the two (2) stock M8 hex bolts, install the new **Upper A-Arms** as shown and torque to 30 ft·lb (41 N·m). The shock mounting bracket will be facing up and the bend is oriented toward the front.

Once installed, reinstall the steering rack to the vehicle using the three stock bolts from STEP 3 and torque to 22 ft·lb (30 N·m).

NOTE: Grease fittings (A) of upper A-arms after installing and before the next step.

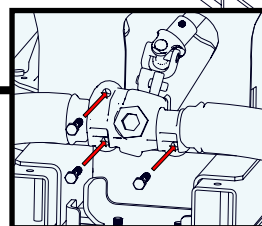
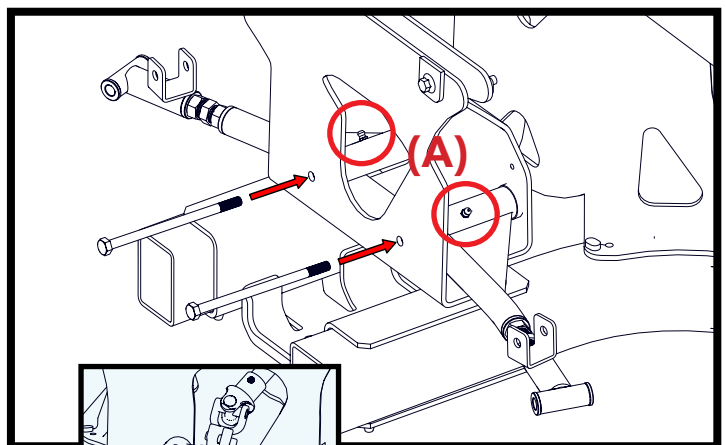

STEP 7

 17mm SOCKET

Using the tow bar bracket removed in Step 5, four (4) M10 x 55mm hex bolts, four (4) M10 flat washers, and four (4) M10 lock washers, mount the **Main Suspension Assembly** to the underside of the vehicle frame as shown. Use thread lock adhesive on bolts once they are started into cart frame. Using a crisscross pattern sequence, torque bolts to 37 ft·lb (50 N·m).

The Main Suspension Assembly is sandwiched between the tow bar bracket and the vehicle frame.

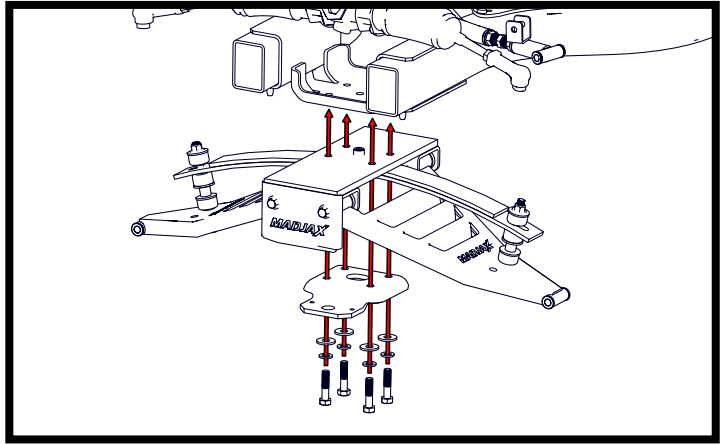

NOTE: DO NOT adjust the bushing assemblies at the end of the leaf springs. These bolts are preset to the proper tightness. It will not appear tight until the weight of the vehicle is on the suspension.

STEP 8

 17mm WRENCH & SOCKET

Using four (4) M10 x 80mm hex bolts, eight (8) M10 flat washers, and four (4) M10 nylock nuts, install each **Spindle**.

The steering arm of the spindles will be oriented to the front of the vehicle and grease fitting to rear as shown.

NOTE: Grease fittings (A) on outer end of both top and bottom A-arms after installing and before the next step.

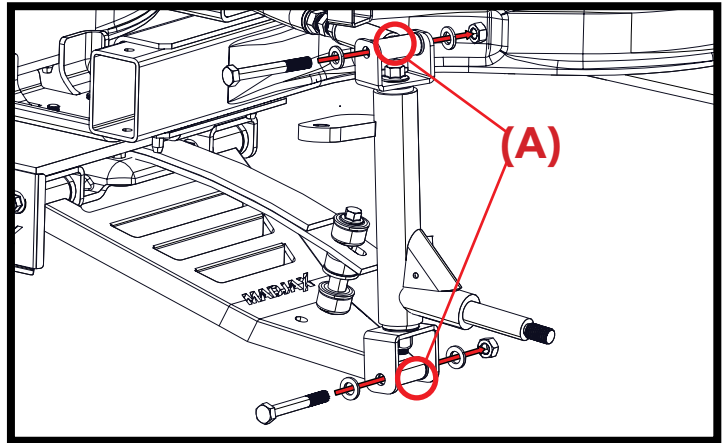

STEP 9

 13mm WRENCH & SOCKET

Attach the stock front shocks to the shock mounting location on each upper A-Arm using two (2) M8 x 50mm hex bolts, four (4) M8 flat washers, and two (2) M8 nylock nuts.

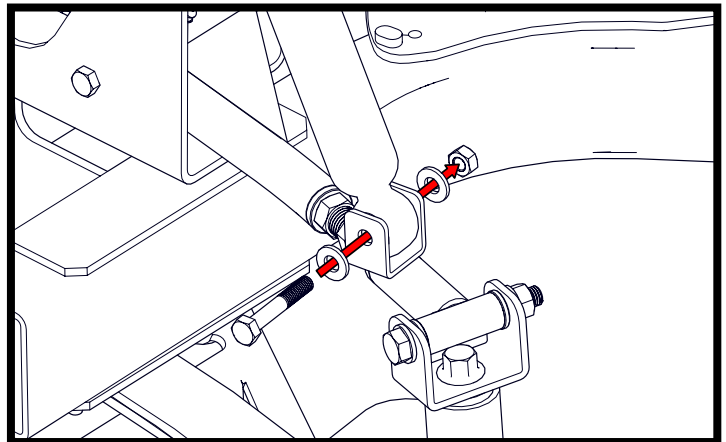

STEP 10



17mm WRENCH &
18mm SOCKET

Using the stock nuts, install the steering rack tie rods to the steering arms of each spindle.

Once the nut is tightened, install one (1) cotter pin through the hole in the threaded stud of the tie rod on each sides of the vehicle. Use pliers to grab a split end of the pin and bend it around the bolt. Do this for the other end, as well. Then use the pliers to squeeze the ends until they are secure around the nut and bolt connection.

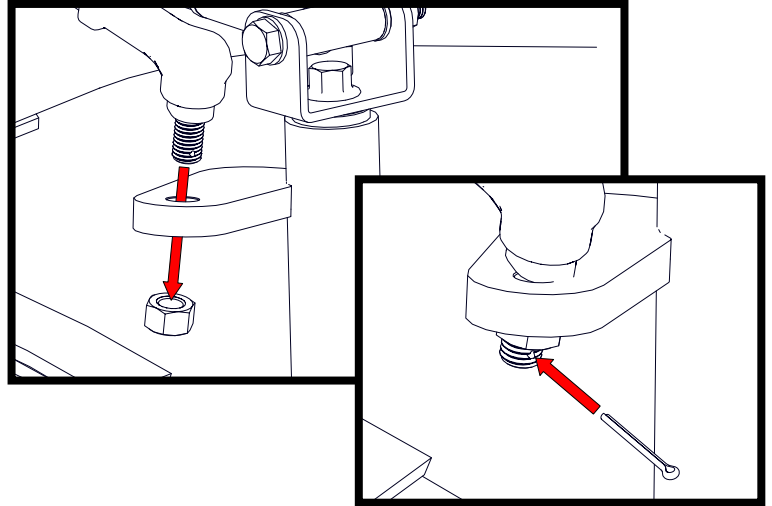

STEP 11



13mm, 19mm, and 13/16"
SOCKETS, 10mm WRENCH

Using the stock hardware, reinstall the hubs, bumper, and new wheels/tires to the vehicle.

Torque the hub nuts to 50 ft-lbs

Torque the lug nuts to 55 ft-lbs

Remove the jack stands and lower the vehicle to the ground. We recommend installing 22"-23" tires on 6" lift kit and 20" tires on 4".

NOTE: DO NOT attempt to align or adjust toe/camber until rear lift is installed and cart has been test driven.



STEP 12



19mm SOCKET

Loosen the rear lug nuts before lifting rear of cart.

Chock the front tires and disengage the parking brake. Lift the rear of the vehicle and support the frame with jack stands.

Remove the rear wheels. Place the jack under the rear axle to support the axle as needed during installation.

NOTE: Failure to support rear axle with floor jack could potentially damage rear end.

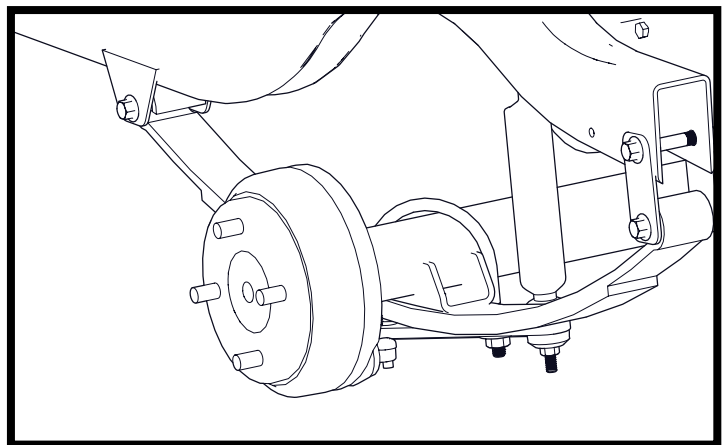

IMPORTANT: When installing the rear lift, ONLY install one side at a time. DO NOT attempt to install both sides at once. Step 13 will be to loosen the driver's side only first and then move over to the passenger side to complete the full install.

STEP 13



5/8" SOCKET

Loosen, but do not remove the nuts on the stock u-bolts on the **driver's side** only. (Orientation does not matter)

This will allow enough adjustment while installing the rear lift kit on the passenger's side.

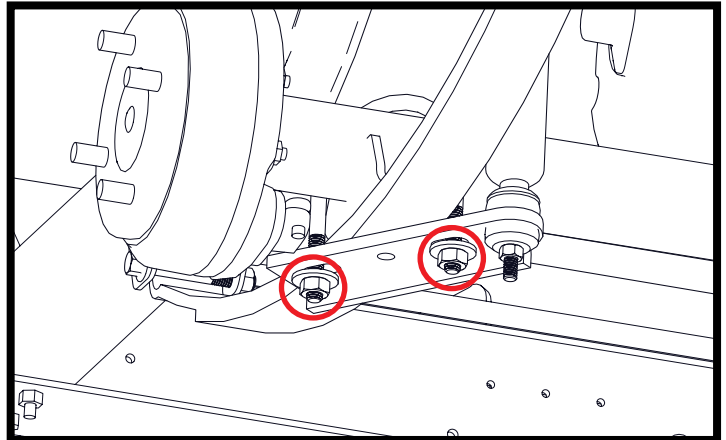

STEP 14



5/8" and 9/16" SOCKETS

Complete steps 14-19 on the **passenger's side** before moving back to the driver's side.

Remove the stock u-bolt holding the axle to the leaf spring on the passenger's side. Also remove the nut and lower bushing of the rear shock, allowing the removal of the stock shock mounting bracket.

The u-bolt and its two nuts will be discarded. The shock hardware and the stock mounting bracket must be retained for later use.

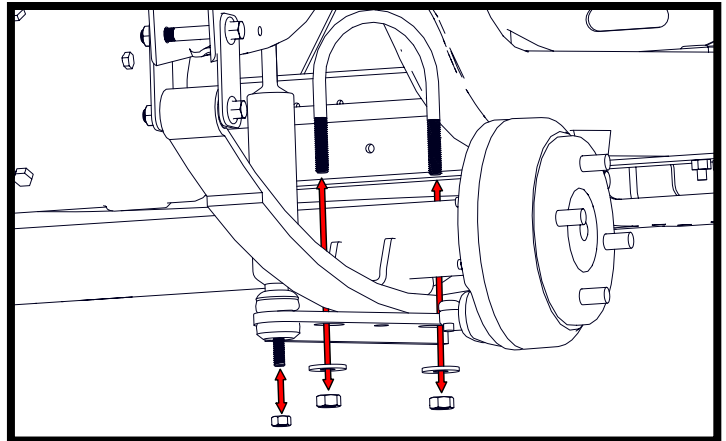

STEP 15



10mm SOCKET &
13mm WRENCH

Support the weight of the axle using the floor jack but do not lift axle.

Remove and retain the hardware from the **passenger's side** leaf spring and remove the leaf spring from the vehicle.

Temporarily remove the brake line from the front leaf spring mounting bolt when removing the spring.

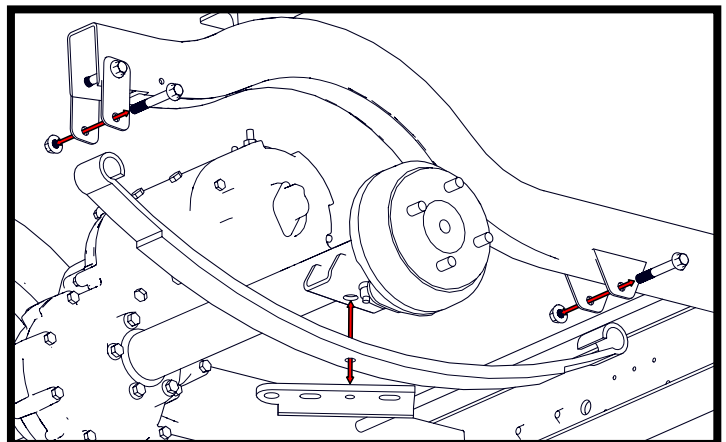

NOTE: Now is a good time to replace leaf springs and/or shock bushings if needed.

STEP 16



10mm SOCKET &
13mm WRENCH

Use the floor jack to lower the driver's side of the rear axle.

Use the stock hardware to reinstall the leaf spring (or new HD leaf springs, recommended with rear seat kit), above the rear axle as shown. Torque spring mounting bolts to 18.5 ft·lb (25 N·m).

Reinstall the brake line clamp to the front leaf spring mounting bolt. The brake clamps may need to be slightly adjusted forward to reattach due to lift.

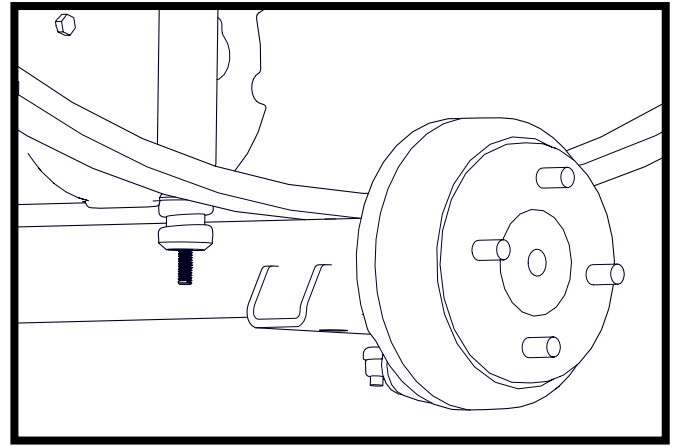

NOTE: The axle alignment bolt in the leaf spring is not centered and should be offset further to the rear of the vehicle. If installed backwards the rear axle will push too far forward and cause tires to rub against tire well.

STEP 17



6mm ALLEN WRENCH &
13mm SOCKET

Install one (1) M8x25mm socket head cap screw and two (2) M8 flat washers to the center hole of the stock shock bracket and secure with one (1) M8 nylock nut.

The head of this bolt should be on the top of the bracket as shown and will locate in the hole of the spring plate on the rear axle in the next step.

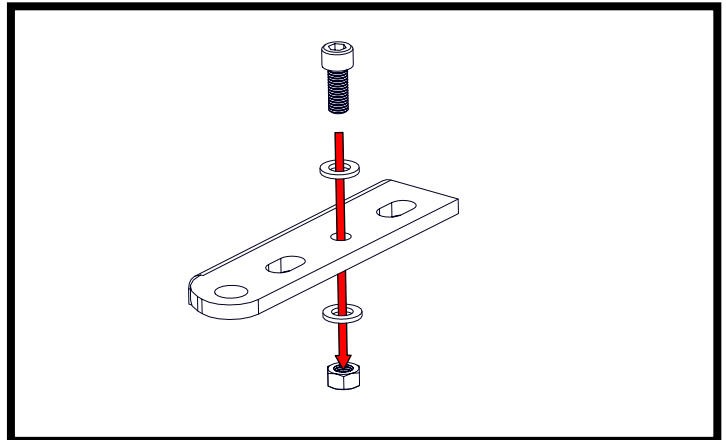

SHOWN OFF VEHICLE FOR CLARITY

STEP 18

Place the rear riser block under the leaf spring and over the axle.

IMPORTANT: If installing a 6" lift with HD leaf springs, the **Short Riser Block** will be used. If installing a 6" lift with standard leaf springs, the **larger, angled riser block** will be used, and the riser must be oriented with the downward angle toward the front of the vehicle, as shown.

Place the new **Shock Mounting Plate** on top of the leaf spring. The shock mounting hole will be oriented to the inside and rear of the vehicle. The stock shock bracket will mount to the bottom of the rear axle, with the head of the socket head cap screw (installed in the previous step) in the locating hole on the axle, as shown.

Ensure block angles
toward front of cart.

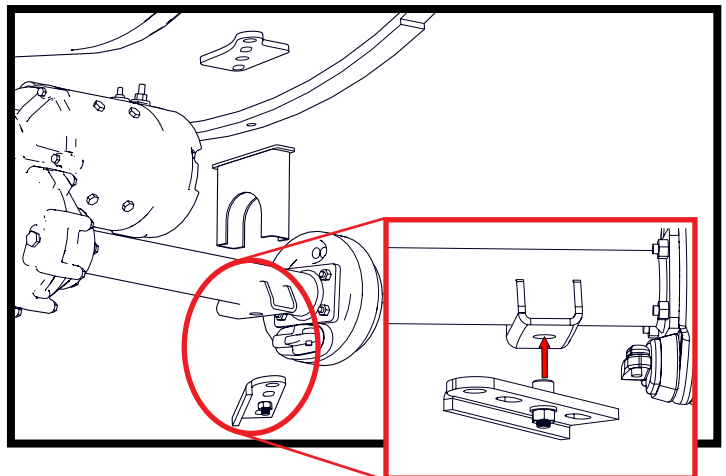

NOTE: The 16-051 lift kit only uses the short blocks which have no angle.

STEP 19

 17mm DEEP WELL SOCKET
& 9/16" SOCKET

Secure all parts to the axle using one (1) M10 square u-bolt, two (2) M10 flat washers and two (2) M10 nylock nuts. Alternate tightening each side to ensure even clamping. Torque nuts to 25 ft·lb (34 N·m). Use the floor jack to pickup axle and assist with positioning.

Secure rear shock to new **Rear Shock Plate** using the stock hardware. Tighten the nuts until the rubber bushing expands to the size of the cup washer.

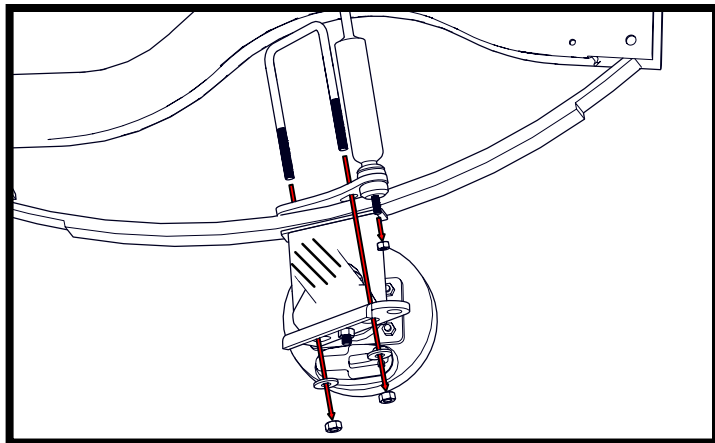

STEP 20

Repeat steps 14-19 on the **driver's side** of the vehicle using the jack to adjust the axle position as needed.

Make sure all lines and cables running to the engine and rear axle have enough length for safe operation, and adjust as needed.

Install new wheels/tires.



STEP 21

 19mm SOCKET,
TORQUE WRENCH

Lower the vehicle to the ground and torque all lug nuts to 55 ft-lbs.



STEP 22



19mm WRENCH x 2

On flat, level ground, use a large framing square to check and adjust the camber of each front wheel until the tire is perpendicular to the ground.

To adjust, loosen the jam nuts on each side of upper a-arm turnbuckle. Use a wrench to turn the center of the turnbuckle in or out as needed. Continually check the camber with the framing square as you turn the turnbuckle.

Once properly adjusted, tighten each jam nut out against the upper a-arm (not against the center of the turnbuckle).

Repeat on the opposite side of the vehicle.

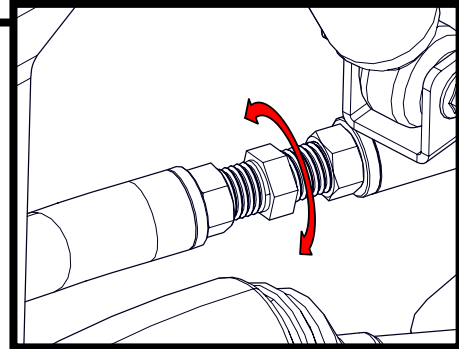

STEP 23



17mm and 12mm WRENCH

Ensure the steering wheel is straight to begin adjusting the toe of the front tires. The measurement between the center of the tread of the two front tires at the front should be $1/8$ "- $1/4$ " **shorter** than the same measurement at the back of the tires.

To adjust, loosen the jam nut on either side of each steering rack. Turn the extension to adjust in or out as needed and recheck the measurement front and back. Also, ensure that the measurement from the front of each tire to the center of the vehicle is the same on both sides and adjust accordingly.

Once the toe is corrected, tighten the jam nuts on both steering arms.

Test drive vehicle and check camber and toe measurements again. If needed, adjust accordingly, adjusting camber first before toe. Retighten all hardware.

Loosen and adjust steering wheel to be straight if needed and re-tighten.

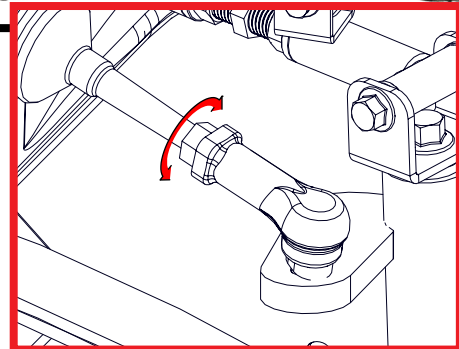

STEP 24

Place the included warning label in a highly visible area on the vehicle for all users to read before operating the vehicle (recommend foot board as shown or steering wheel).



STEP 25



1/2" WRENCH

If you need to adjust the brake tension, remove the floor mat and pedal assembly cover to access the turnbuckle shown.

First, loosen the forward most jam nut by turning it towards the drivers side of the cart. Then rotate the turnbuckle using a wrench towards the drivers side to tighten or passengers side to loosen the brake tension as needed.

After adjusting, check the Parking Brake and ensure that it clicks twice for full engagement. Once properly adjusted, retighten the forward jam nut to the turnbuckle (also check that the rear jam nut has not come loose) and replace cover and floor mat.

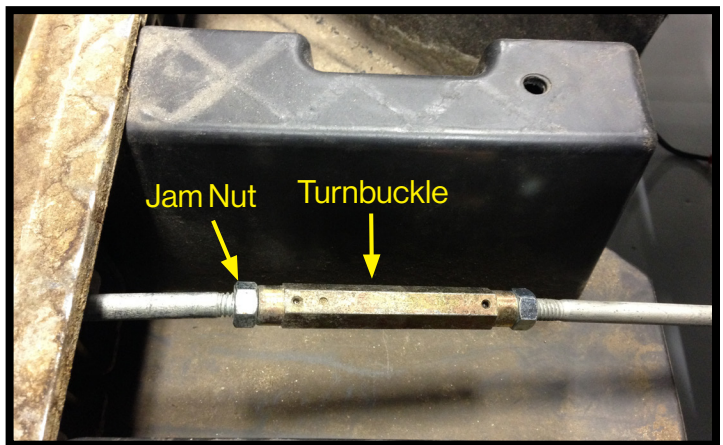
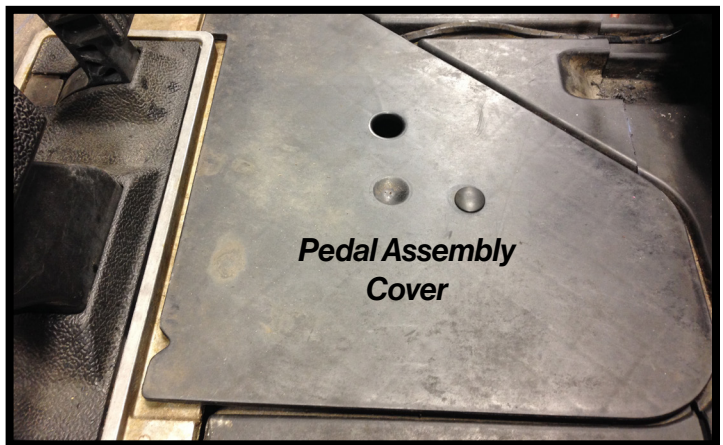

IMPORTANT: These instructions should be kept and stored in this cart for future reference on how to adjust toe/camber, brakes, and re-grease of front lift components.

INSTALLATION COMPLETE

E-Z-GO®, TXT®, RXV® and S4® are registered trademarks of Textron Innovations, Inc. Club Car®, Precedent®, DS®, Onward® and Tempo® are registered trademarks of Ingersoll Rand, Inc. Yamaha®, Yamaha® Drive®, Drive2®, G-14®, G-16®, G-19®, G-22® and G-29® are registered trademarks of Yamaha Golf-Car Company. Any reference to Club Car®, E-Z-GO®, or Yamaha® or their associated trademarks, word marks, and products are only for purposes of identifying golf carts with which this MadJax product is compatible. MadJax products are aftermarket parts and are not original equipment parts. MadJax is not connected to, affiliated with, sponsored by, or endorsed by either Textron Innovations, Inc., Ingersoll Rand, Inc., Yamaha Golf Cart Company, or any of their parent or subsidiary companies.

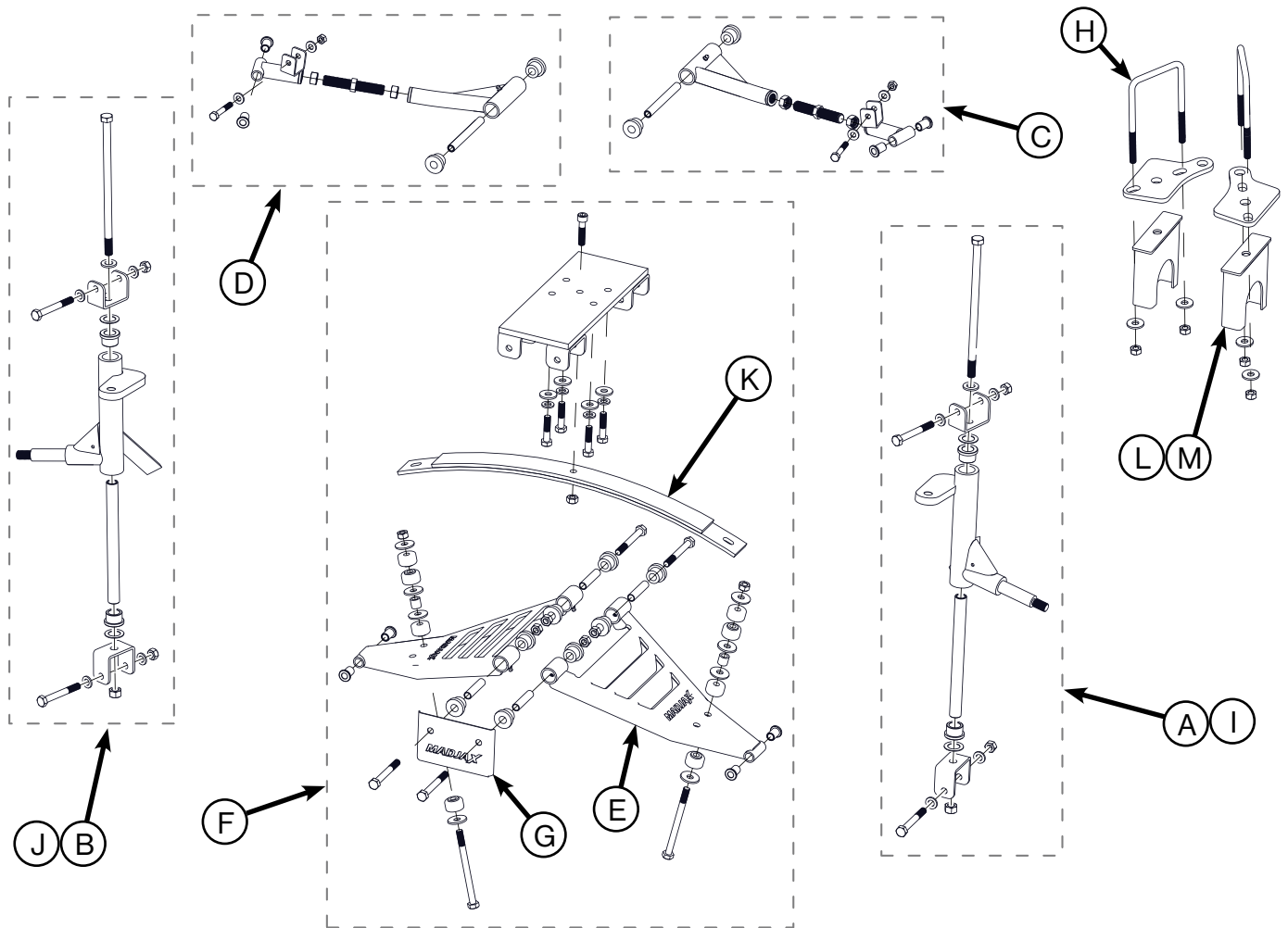

ITEM	PART NUMBER	DESCRIPTION
A	W16-50-1	DRIVER'S SIDE 6" SPINDLE ASSEMBLY w/ KING BOLT & SHACKLES
B	W16-50-2	PASSENGER'S SIDE 6" SPINDLE ASSEMBLY w/ KING BOLT & SHACKLES
C	W16-50-3	DRIVER'S SIDE UPPER A-ARM ASSEMBLY w/ BUSHINGS
D	W16-50-4	PASSENGER'S SIDE UPPER A-ARM ASSEMBLY w/ BUSHINGS
E	W16-50-5	SINGLE LOWER A-ARM ASSEMBLY (UNIVERSAL)
F	W16-50-6	MAIN FRONT SUSPENSION ASSEMBLY
G	W16-50-7	FRONT LOGO PLATE
-	W16-50-8	HARDWARE PACK
-	W16-50-9	UPPER A-ARM ADJUSTMENT BOLT AND NUTS
-	W16-50-10	SINGLE KING BOLT w/ WASHERS & NUTS
H	W16-50-11	M10 x 85mm x 150mm SQUARE U-BOLT W/ WASHERS & NUTS
-	W16-50-12	A-ARM BUSHING PAIR
I	W16-50-13	DRIVER'S SIDE 4" SPINDLE ASSEMBLY w/ KING BOLT & SHACKLES
J	W16-50-14	PASSENGER'S SIDE 4" SPINDLE ASSEMBLY w/ KING BOLT & SHACKLES
-	W16-8-31	LEAFSPRING BOLT
K	W16-1-32	FRONT LEAF SPRING
L	W16-1-38	SHORT REAR LIFT BLOCK
M	W16-1-41	TALL REAR LIFT BLOCK