



# AMP® 12V LED Lamps Single Source MR11 2700K Series

## Product Description

AMP® LED lamps are design match the form factor and illumination of the halogen bulbs they replace.

These lamps are instant-on. Available in both 38° and 60° beam spreads, the lamps are conforming size to fit the need of any application. The MR11's have an estimated life of 40,000 hours.

All AMP® LED lamps are backed by our Lifetime Replacement Warranty (for residential applications); the warranty for commercial projects is 10 years.



## Product Documentation

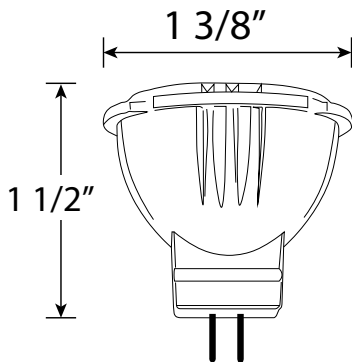

## Features & Benefits

- ▶ Replacements for:
  - 20W Halogen MR11s
  - 38°, and 60° Beam Angles
- ▶ Reduces energy consumption by about 75%
- ▶ Lasts up to 8 times longer than halogen lamps
- ▶ No warm-up time, instant-on with full light output and stable lamp to lamp color

## Specifications

- ▶ **Input Voltage, Frequency:** 6-18VAC, 50/60Hz, with decreased lumens under 10V
- ▶ **Input Power:** 2W or 4W
- ▶ **Beam Angles:** 38° (flood), 60° (wide flood)
- ▶ **Lumen Output:** 150 lm Or 350 lm
- ▶ **Correlated Color Temperature (CCT):** 2700K
- ▶ **Color Rendering Index (CRI):** >83
- ▶ **Life:** 40,000 hours (L<sub>70</sub>)

## Warranty

Residential: Lifetime Warranty  
Commercial: 10-Year Warranty

**Specifications subject to change without notice.**